

SERIES S350-STC

INLINE CHECK VALVE WITH SANITARY ENDS

Stainless steel inline check valve with sanitary triclamp end.

- Sizes 1/2" to 4".
- 1/2 psi cracking pressure.
- Precision machined 316L body, stem and disc.
- 25 Ra polished body and internals.
- Stainless steel spring standard VITON seal ring, EPDM available option.
- 150 PSI @ 250°F (Approx. 121°C).

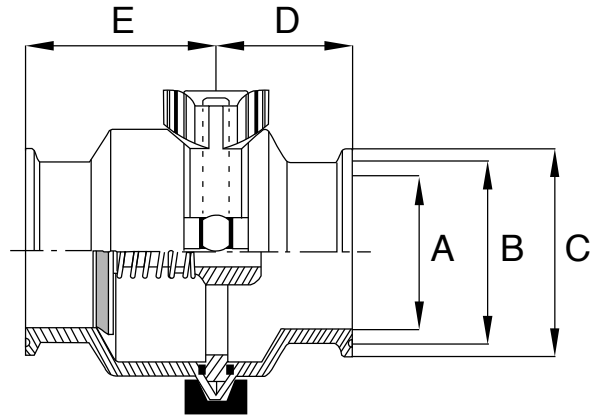
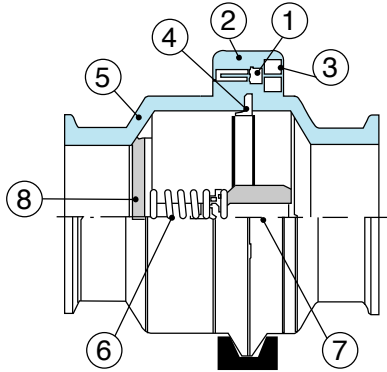

N POS	PART NAME	MATERIAL	N PCS
1	SHORT BODY	SS 316L	1
2	LONG BODY	SS 316L	1
3	SCREW	SS 316	1
4	BODY O-RING	FKM (Viton)	1
5	SEAT RING	FKM (Viton)	1
6	SPRING	SS 316	1
7	FLOW SUPPORT PLATE	SS 316	1
8	DISC	SS 316L	1

SIZE	A	B	C	D	E	Cv	psi	Weight Lbs
1/4"	0.37	0.69	1.00	1.10	1.54	2.3	235	2.20
3/8"	0.63	0.69	1.00	1.10	1.54	6.2	235	2.20
1/2"	0.87	1.71	1.99	1.65	2.32	13.0	235	3.50
3/4"	1.37	1.71	1.99	1.65	2.32	29.0	235	3.50
1"	1.87	2.22	2.52	1.65	2.32	51.0	235	5.40
1 1/4"	2.37	2.78	3.05	1.65	2.32	72.0	150	6.00
1 1/2"	2.87	3.29	3.58	1.65	2.32	95.0	150	6.25
3"	3.82	4.43	4.69	2.32	2.60	170.0	100	16.00